

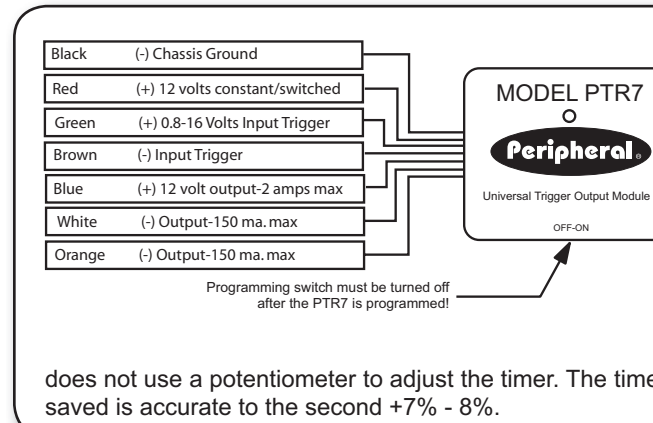

PTR7 Universal Trigger Output Module



The PTR7 is a universal trigger output module that has various user programmable features combined into one unit. The user programmable features are stored in non volatile memory. When triggered, the PTR7 can turn on the outputs as a pulsed, latched or a timed output. There are two inputs, the GREEN wire is a positive input that senses voltages as low as 0.8 volts and the BROWN wire is a negative input, **both are tied together internally which is, essentially, ONE trigger input.** There are 3 separate outputs, the BLUE wire is a positive 12 volt output which has a maximum current rating of 2 amps. The WHITE and ORANGE wires are negative outputs which have a maximum of current rating of 150 milliamps. The timed output is user adjustable and can be programmed up to 4 minutes and 15 seconds. What makes the PTR7 unique is that it

does not use a potentiometer to adjust the timer. The timer is set by programming PTR7 minutes and seconds with a number. The time saved is accurate to the second +7% - 8%.

Basic Description of Features

The basic descriptions below are the features that can be done with the PTR7. Each feature is assigned a Feature#. Please make note of which Feature# you are going to use. Other unique projects/installs can also be derived from the PTR7, so Peripheral leaves it to the installer's imagination to experiment with these features.

- #1: **Low voltage trigger.** Supplies a 12 volt remote output for an aftermarket amplifier when used with a stock head unit that does not have a remote output. Use the PTR7 to supply a 12 volt output from a 5 volt remote source, like from Ford radios. Use on some vehicles that have a negative antenna output and convert to a positive output.
- #2: **Alpine video bypass.** This will automatically bypass Alpine's flip out monitor video safety procedure. **WARNING! It is dangerous (and illegal in most states) for the driver to watch the TV/Video monitor while driving the vehicle. The driver may be distracted from looking ahead and an accident could occur. Install the PTR7 only in RV and Marine applications where there is no parking/hand brake to interface to. Do not install the PTR7 where the driver may be able to view the monitor when driving.**
- #3: **Latch and unlatch output from a pulsed input.** Turn on headlights, neon lights or radio from an alarm with a momentary output or from a momentary switch.
- #4: **Double pulse output.** Pulses outputs twice when trigger from a constant or pulsed signal. Use for alarm applications where the unlock wire needs 2 pulses to unlock all doors.
- #5: **Closed loop circuit.** Good for monitoring trailers on hitches by triggering an aftermarket alarm if the trailer is disconnected from the vehicles hitch. Also monitors stereo equipment in vehicles.
- #6: **Pulse extender/Delayed turnoff.** Upon a constant or pulsed trigger, the PTR7 will turn on the outputs. As soon as the trigger is disconnected, turned off or at the end of a pulse, the timer will count up to the number of seconds recorded, at which time the outputs will turn off. Good for turning on headlights at night for convenience. Extend alarms output from 1 second to 3 seconds for Mercedes vacuum door locks. (rev.2)
- #7: **Horn honking output.** On older, aftermarket alarms, it may have been difficult to disarm the alarm with the RF remote when the horn was honking. This will give you a 2 second delay between honks, allowing you to disarm the alarm. Unique horn honking to distinguish your vehicle from others. Program between 1 and 5 honks before the 2 second delay.
- #8: **Linear Actuator Controller.** Open/close amplifier racks from a momentary source like from a alarm's negative output. Sequence is : Start, Stop, Reverse, Stop.
- #9: **Door lock Pulse generator.** Good for automatically locking and unlocking door locks when ignition is turned on and off.
- #10: **Channel Splitter.** Split 1 channel from an alarm to 2 outputs. Both outputs are user programmable for pulse, latched or timed output.
- #11: **Pulses to constant output.** Counts a number of user programmable pulses within a user programmed time to turn on the outputs. Good for triggering Vehicle tracking devices that need a constant trigger but the factory alarm only has a pulsed output when triggered like flashing lights or horn honking. Keeps factory alarm from triggering Vehicle tracking device when arming or disarming.
- #12: **3 timers in 1.** Upon a constant trigger, all 3 outputs are user programmable to delay before turning on outputs or turning on instantly then delay before turning off outputs. Good for situations where you need more than 1 timer but on a different timer period, without having multiple modules.
- #13: **Pulses to latch/unlatch outputs.** Upon a number of pulses within a user programmable time, the outputs will latch. Upon a number of pulses within a user programmable time the second time, the outputs will unlatch. You may program how many pulses to latch and unlatch. Use to turn on aftermarket driving lights by using existing parking light switch.
- #14: **Pulses to pulse output.** Upon number of pulses within a user programmable time, the outputs will pulse. Example, if you programmed to see 4 pulses, for every 4 pulses the PTR7 sees within a 5 second time period, the outputs will pulse once.
- #15: **Pulses to timed output.** Upon a number of pulses within 5 seconds, the outputs will turn on and delay for the amount of programmed time, then the outputs will turn off.
- #16: **Latching outputs #2.** Good for turning on 2 sets of driving lights with one momentary switch. 1st pulse will latch one wire. 2nd pulse will unlatch first wire and latch second wire. 3rd pulse will latch both wires. 4th pulse turns off both wires.

PTR7 Flowchart

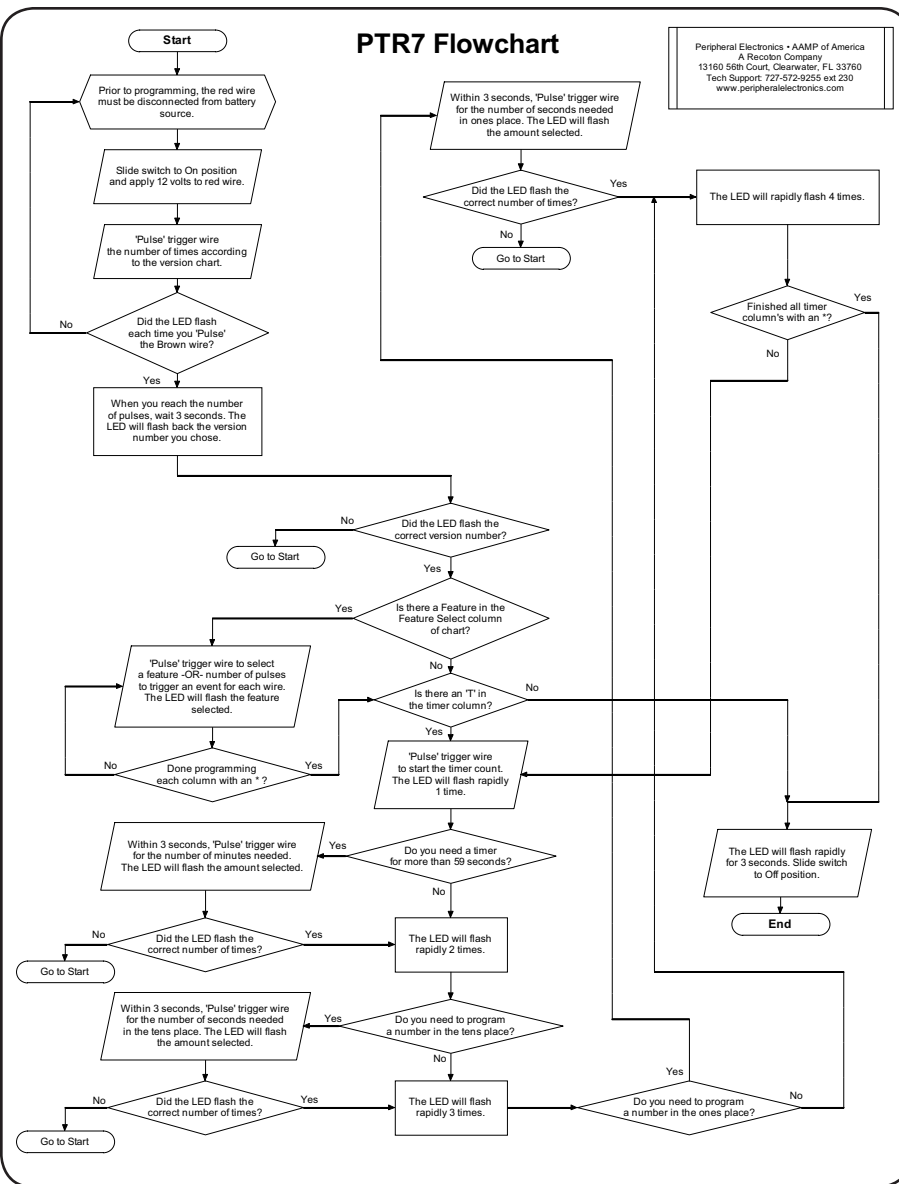

Peripheral Electronics • AAMP of America
A Racaltron Company
13160 56th Court, Clearwater, FL 33760
Tech Support: 727-572-9255 ext.230
www.periphralelectronics.com

Remember to always fuse all 12 volt sources when using relays.

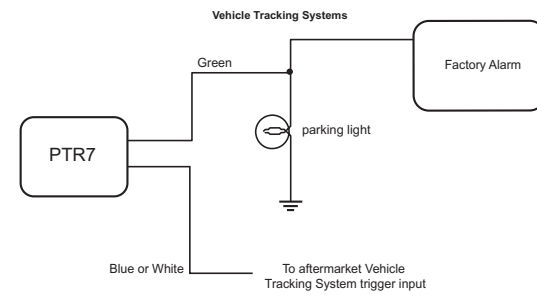

Low voltage trigger, +12v output

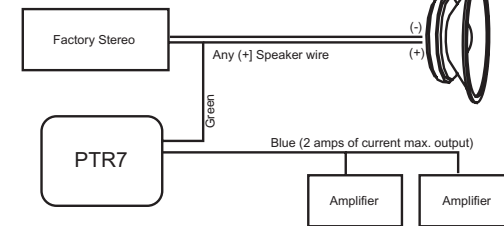

Linear Actuator Controller

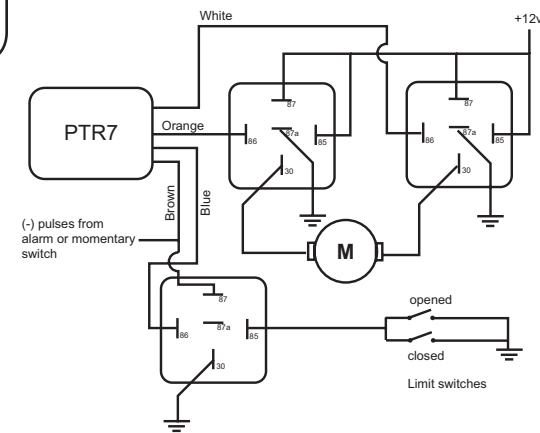

Siren Chirp Eliminator

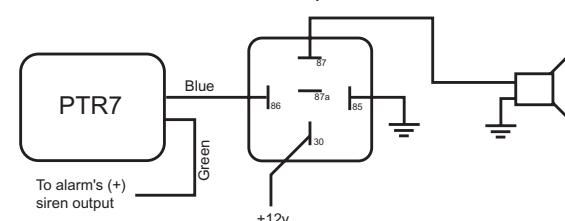

Ignition Controlled doorlocks

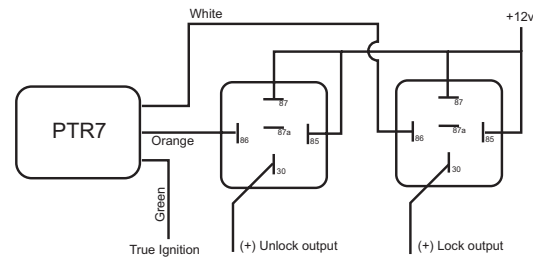

Horn honk

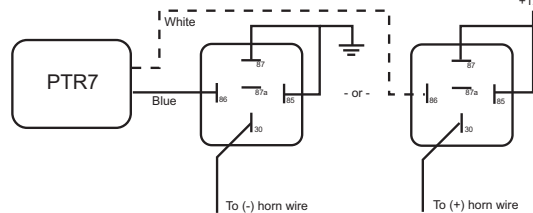

Feature Chart										
Feature	Feature#	Feature Select			Timer			Outputs used		
		Blue	White	Orange	Blue	White	Orange	Blue (+)	White (-)	Orange (-)
Low voltage trigger	1								M	
Alpine video bypass (factory default)	2								M	
Latching on / off outputs	3								M	
Double pulse	4								M	
Closed loop trigger	5					T			M	
Pulse extender	6					T			M	
Horn honk	7	count number of pulses to pulse output							M	
Linear actuator controller	8							x	x	x
Doorlock pulse generator	9			unlock = 1, no unlock = 2					x	x
Channel splitter	10		pulse = 1, latch = 2, timer = 3	pulse = 1, latch = 2, timer = 3		T	T		x	x
Number of pulses for constant output	11	count number of pulses for trigger				T			M	
3 programmable timer outputs on constant trigger	12	delayed on = 1, delayed off = 2	delayed on = 1, delayed off = 2	delayed on = 1, delayed off = 2	T	T	T	x	x	x
Number of pulses to latch / unlatch output	13	1. Count # of pulses to latch output • 2- Count # of pulses to un-latch output				T			M	
Number of pulses to pulse output	14	count number of pulses to pulse output				T			M	
Number of pulses for timer output	15	count number of pulses for timer output				T			M	
Latching outputs #2	16								x	x

M = Married wires. Both wires either pulse, latch/unlatch or time at the same time. **T** = Timer. Indicated wires must be programmed with a time.

Detailed Description and Wiring Instructions

PLEASE READ!

1. Connect the BLACK wire to chassis ground.
2. Connect the RED wire to switched +12volts. (After programming, the RED wire can be left on switched or wired to constant +12volts)
3. Go to Page 3 and program the PTR7 with the selected Feature # you need. Return here to finish wiring the PTR7.

- #1: On a constant trigger, both the BLUE and WHITE wire will activate after a one second delay. If you are using the PTR7 to turn on an amplifier, you can connect the GREEN wire to any (+) speaker wire lead and the BLUE wire to the amplifier's remote input. If you need to invert a negative to a positive output, connect the BROWN wire to the source and the BLUE wire to the device that needs to see a positive signal to activate. The BLUE wire can connect directly to 1 to 4 devices that have a remote trigger input. If the total current draw of the devices exceed 2 amps, use a relay to supply 12 volts at a higher current.
- #2: This will automatically bypass Alpine's video safety procedure. After programming (detailed programming on page 3), connect the GREEN wire to the Alpine's remote wire, the BLUE wire to the Alpine's foot brake input wire, the WHITE wire to the Alpine's parking brake input wire. In this configuration, relays are not needed. Do not connect any other sources to the WHITE or BLUE wires of the PTR7. Connect the RED wire to vehicle's accessory 12v. **Note: This feature is factory set. Keep switch to off position and wire according to above. No programming is necessary unless changed. WARNING! It is dangerous (and illegal in most states) for the driver to watch the TV/Video monitor while driving the vehicle. The driver may be distracted from looking ahead and an accident could occur. Install the PTR7 only in RV and Marine applications where there is no parking/hand brake to interface to. Do not install the PTR7 where the driver may be able to view the monitor when driving.**
- #3: Connect the BROWN or GREEN wire to a momentary source, like from a switch or alarm's output. When triggered, the BLUE and WHITE wire will turn on and stay on. When triggered a second time, the BLUE and WHITE wires will turn off. Use the BLUE or WHITE wire to activate a relay to turn on lights, neon, or any other source that draws high current.
- #4: Connect the BROWN wire to the alarm's unlock output and connect the BLUE wire or WHITE wire to the unlock wire of the vehicle that needs to see 2 pulses to unlock all doors.
- #5: Extend the BROWN wire and connect to the chassis of the trailer or the back of stereo in such a way that the BROWN wire must be cut or disconnected from the chassis, if a theft is in progress. The BROWN wire must be connected to a good chassis source so that it will not false trigger. Connect the BLUE or WHITE wire to an alarm or other alarming device trigger input. You may program a delayed time before the outputs will turn on when the BROWN wire is disconnect from the chassis.
- #6: Connect the BROWN or GREEN wire to a pulsed or constant source. Connect the BLUE or WHITE wire to the device that you want to activate for a time period. You may program a delayed off time. The delay will not start until the end of the pulse or when the constant trigger is off.
- #7: Connect the BROWN or GREEN wire to the siren output of the alarm. Connect the BLUE or WHITE wire to a relay that will supply a positive or negative output to the horn wire. When triggered, the PTR7 will delay 2 seconds before honking the horn. Although this is not a full Linear Actuator Controller (does not have a brake wire), the PTR7 will brake correctly when used with limit switches. If wired according to the diagram on the diagram page, the linear actuator will function and work correctly. Connect the BROWN or GREEN wire to a momentary source. When pulsed the first time the WHITE wire will latch on, then 1.5 seconds later the BLUE wire will latch on (this will allow time for the limit switches to turn off) . On a second pulse both the BLUE and WHITE wire will turn off. On a 3rd pulse the ORANGE wire will latch on, then 1 second later the BLUE wire will latch on.
- #8: Connect the BLUE, WHITE and ORANGE wires to relays as indicated below for the selected Feature #. !! Do not connect the BLUE, WHITE or ORANGE wires to devices directly unless instructed.
4. Always use a fuse when using relays with a +12 volt source!
- #9: Connect the GREEN wire to a true ignition wire of the vehicle. Connect the WHITE wire to the lock relay and the ORANGE to the unlock relay. When the ignition is turned on, the WHITE wire will pulse once after a 5 second delay. When the ignition is turned off, the ORANGE wire will pulse once. The ORANGE wire is user programmable not to pulse when the trigger is disconnected.
- #10: Connect the BROWN wire to the alarm's negative output. Connect the WHITE wire to the first device being controlled and the ORANGE wire to the second device being controlled. Use relays if the devices draw more than 150 milliamps. After a single pulse from the alarm within 3 seconds, the WHITE wire will activate. After two pulses within 3 seconds, the ORANGE wire will activate. Each wire is user programmable for a pulse, latch or a timed output. Please note that if any one of the two wires are programmed for a timer output, the PTR7 will not respond until the timer is finished.
- #11: Connect the GREEN or BROWN wire to the factory alarm's flashing light or horn output. Connect the BLUE or WHITE wire to the vehicle tracking device trigger input. You can program the amount of pulses the PTR7 sees within a user programmable number of seconds to trigger the vehicle tracking device. **Example;** if the factory alarm flashes or honks the horn a maximum of 2 times when arming or disarming, then you may program the PTR7 to see a minimum of 4 pulses within a 5 second period to trigger the PTR7 which will turn on the BLUE and WHITE wire. As long as the pulses continue, the PTR7 BLUE or WHITE wire will stay on.
- #12: Connect the BROWN or GREEN wire to a source that stays constant when turned on. Connect the BLUE, WHITE and ORANGE wire to the devices being controlled. Both outputs are user programmable to delay before turning on the outputs or programmable to turn on outputs instantly, then delaying before turning off. You do not need to use all the outputs, but during programming you do need to program all features and timers before you can automatically exit programming.
- #13: Connect the GREEN or BROWN wire to a momentary or pulsed source. Connect the BLUE or WHITE wire to a device being controlled. Upon seeing a number of pulses within a number of seconds the first time, the outputs will latch. After seeing a number of pulses within a number of seconds the second time, the outputs will unlatch. You may program how many pulses the PTR7 needs to see to latch and unlatch the outputs. **Example;** turn on and off your parking lights 4 times within 5 seconds to turn on aftermarket lights. Turn on and off 3 times within 5 seconds to turn the aftermarket lights off.
- #14: Connect the GREEN or BROWN wire to a pulsed output source. Connect the BLUE or WHITE wire to a device being controlled. Upon seeing a user programmable number of pulses within a user programmable number of seconds, the BLUE and WHITE outputs will pulse once. Example, if you programmed the PTR7 to see 4 pulses within 7 seconds, then for every 4 pulses the PTR7 sees within 7 seconds, the outputs will pulse once.
- #15: Connect the GREEN or BROWN wire to a pulsed output source. Connect the BLUE or WHITE wire to a device being controlled. Upon a user programmable number of pulses the PTR7 sees within 5 (non adjustable) seconds, the BLUE and WHITE outputs will turn on and delay for a user programmable time, then the outputs will turn off.
- #16: Connect the BROWN or GREEN wire to a momentary source. Connect the BLUE or WHITE wire to the device being controlled. On the first pulse the PTR7 receives, the WHITE wire will latch on. On the second pulse the WHITE wire will unlatch and the ORANGE wire will latch on. On the third pulse, the WHITE and ORANGE wires will latch on. On the fourth pulse both the WHITE and ORANGE wire will turn off.

Programming the PTR7 with a Feature Number

Please READ! Many technical phone calls can be avoided by reading this section thoroughly.

• In the instructions below, when asked to 'Pulse' the trigger wire, this will indicate to temporarily ground the BROWN wire to chassis ground and then un-grounding it. Each time you do this, the LED indicator will turn on and off.

• All 'Feature Select' and 'Timer' section in the chart MUST be programmed from a left to right order. Even if you do not need all the outputs of the PTR7, an option or time must be set for that wire in order for the PTR7 to finish programming.

• If you do not understand this written part of the instructions, you can use the flow chart on page 4. The flow chart will help you program the PTR7 step by step.

Feature Number: _____
write Feature number here

1. Select a feature you want from the chart and write down the Feature above. Slide the switch to the on position and apply 12 volts to the PTR7 RED wire. 'Pulse' the trigger wire the number of times of the selected Feature number. Wait 3 seconds, and the LED will flash the amount of times you 'Pulsed' the trigger wire saving that Feature number into memory.

note: If you are doing Feature# 1 through 4, 8 or 16, you may go directly to step #4 after you do step #1.

2. When selecting a feature, 'Pulse' the trigger wire once to select the 1st option, twice within 3 seconds to select the 2nd option, or 3 times within 3 seconds to select the third option. **Example; Feature# 9, 10, and 12 need an option selected.**
- OR -

If you need to select how many pulses you need to trigger an event, 'Pulse' the wire the number of times needed. **Example; Feature# 7, 11, 13, 14, and 15 need a number of pulses to trigger an event.**

After 3 seconds, the LED will flash the amount of times you 'Pulsed' the trigger wire telling what option you selected or how many pulses the PTR7 needs for a triggered event. Repeat if other wires need to have an option selected. After all remaining options are programmed in the '**Feature Select**' section, the PTR7 will automatically go to the '**Timer**' section.

3. In the '**Timer**' section in the chart, where a '**T**' is indicated, you will need to program a time for that specific wire(s). If in the '**Feature Select**' section you programmed for a pulse or latched event for that color wire, then the timer for that wire will be automatically skipped because the timer is not needed.

To start programming the time needed, 'Pulse' the trigger wire one time to start the timer...

Minutes: The LED will flash rapidly 1 time, indicating you need to program the number of minutes. 'Pulse' the trigger wire for the number of minutes needed. After 3 seconds the LED will flash the number of minutes recorded. If you program for 5 or greater, the PTR7 will default to 4 for minutes. If you need zero minutes, do nothing and wait the 3 seconds.

Seconds in tens place: The LED will flash rapidly 2 times indicating you need to program the number of seconds in the tens place. 'Pulse' the trigger wire the number of seconds needed. After 3 seconds the LED will flash the number of seconds recorded in the tens place. If you program for 6 or greater, the PTR7 will default to 5 for the tens place. If you need zero seconds in the tens place, do nothing and wait the 3 seconds.

Seconds in ones place: The LED will flash rapidly 3 times indicating you need to program the number of seconds in the ones place. 'Pulse' the trigger wire the number of seconds needed. After 3 seconds the LED will

flash the number of seconds recorded in the ones place. If you program for 10 or greater, the PTR7 will default to 9 seconds for the ones place. If you need zero seconds in the ones place, do nothing and wait the 3 seconds.

End of timer: The LED will flash rapidly 4 times indicating that the timer is finish recording. Repeat step 3 if more than one timer has to be recorded, otherwise go to step 4.

Example 1; If you want 36 seconds for a timer, 'Pulse' the trigger wire one time. The LED will flash rapidly 1 time, wait 3 seconds and 0 minutes will be recorded. The LED will flash rapidly 2 times, 'Pulse' the trigger wire 3 times, after 3 seconds the LED will flash 3 times indicating 3 was recorded for the tens place. The LED will flash rapidly 3 times, 'Pulse' the trigger wire 6 times and after 3 seconds the LED will flash 6 times indicating 6 was recorded for the ones place.

$$36 \text{ seconds -or- } 0:36 = \frac{0}{\text{min}} \frac{3}{\text{tens}} \frac{6}{\text{ones}}$$

Example 2; If you want 2 minutes and 25 seconds for a timer, 'Pulse' the trigger wire one time. The LED will flash rapidly 1 time, 'Pulse' the trigger wire 2 times, after 3 seconds the LED will flash 2 times, indicating 2 was recorded for the minutes place. The LED will flash rapidly 2 times, 'Pulse' the trigger wire 2 times, after 3 seconds the LED will flash 2 times indicating 2 was recorded for the tens place. The LED will flash rapidly three times, 'Pulse' the trigger wire 5 times, after 3 seconds the LED will flash 5 times indicating 5 was recorded for seconds in the ones place.

$$2 \text{ minutes and } 25 \text{ seconds -or- } 2:25 = \frac{2}{\text{min}} \frac{2}{\text{tens}} \frac{5}{\text{ones}}$$

Note: The maximum time that can be set is 4 minutes and 15 seconds. If you go beyond the maximum time, the PTR7 will automatically use 4 minutes and 15 seconds as a time. In Feature # 10, if you did not program for any timers, then the 'Timer' section will automatically be skipped.

4. After all options and/or timers are programmed, the LED will flash rapidly for 3 seconds, indicating that programming is finished. **Slide the switch to the OFF position.** If you make a mistake during programming, you will need to start over from step 1.
5. Return to the previous section to finish wiring the PTR7.

Programming for Alpine Bypass

1. Connect the black wire to chassis ground and connect the red wire to 12v accessory.
2. Slide the PTR7 switch to the ON position and turn the ignition on.
3. Ground the brown wire 2 times and wait 3 seconds. The LED will flash 2 times for confirmation. The LED will rapidly flash for 3 seconds.
4. Slide the switch to the OFF position.
5. Connect the green wire to the Alpine's blue/wht wire, the blue wire to the Alpine's footbrake input and the white wire to the Alpine's handbrake input.
6. The PTR7 will automatically bypass the video safety when the radio is turned on.