

The GMAHLANB is a plug and play interface that allows replacement of a General Motors GMLAN factory radio. It will maintain operation of the OnStar® system, Bose® amplifier and speakers. The GMAHLANB has on board switching to allow audio from the OnStar® system to play through the two front factory speakers when OnStar® is active. This interface retains all warning chimes, the audible turn signal indicators, and the Vehicle Rear Parking Assist System (if equipped). Rear Seat Audio headphone jacks will also remain active and are designed for use with dual zone radios.

- OnStar® active LED and Ignition on LED.
- Provides +12v swltched accessory output. No more searching for switched +12v in fuse box or kick panel.
- OnStar® Volume control via factory steering wheel audio controls on Premium Bose® vehicles. Steering wheel radio controls can be retained to control new radio by using the PESWI - X, AKJ, ECL or PS.
- New radio will operate with the vehicle RAP (Retained Accessory Power) system. The radio stays on after the key is turned off and stays on for approximately 10 minutes or until the drivers door is opened.

### Notes

1. The GMAHLANB does not retain the factory XM receiver. You will lose the XM option when the factory radio is replaced with an aftermarket radio.
2. You may use this interface if the vehicle does not have OnStar® but you need to interface with the Bose® amplifier.
3. If you are not retaining the Bose® amplifier, use the GMAHLAN interface instead of this GMAHLANB interface.
4. This interface retains the 5.1 audio system in the Cadillac Escalade.
5. Built in Smart Mute Circuitry will play OnStar® through the front speakers and allow the Rear Seat Audio jacks to continue playing the source selected at the radio.

### Supported Vehicles

#### The Following General Motors Vehicles using the GMLAN Data Bus

**Chevrolet:** Suburban (2007) Tahoe (2007) Avalanche (2007) Monte Carlo (2006-2007) Silverado - not classic (2007) Impala (2006-2007)

**GMC:** Yukon Denali (2007) Yukon (2007) Sierra - not classic (2007)

**Cadillac:** Escalade - including ESV and EXT (2007)

**Buick:** Lucerne (2006-2007)

### Installation

**Step 1-** Pre wire the RAD-18 wire harness to the aftermarket stereo wire harness. Refer to installation notes on page 3 for special instructions

**Step 2-** After connecting the RAD-18 and OS-GM14 wire harness to the GMAHLANB main interface, connect the OS-GM14 connector to the factory harness.

**Note: The Blue/White remote wire must be connected to the new radios amp remote turn on wire.**

The Blue wire is a SWC output wire. Do not connect this wire to anything other than the green interface wire of a PESWI - X, AKJ, ECL, or PS. Program the SWC interface for version #2. When pushing the steering wheel buttons during programming, a simple press and release of the button will do just fine, no need to hold. The rear controls (if equipped) will perform the same functions as the steering wheel buttons without any additional programming necessary. If steering wheel controls are not retained or present, isolate this wire and do not use!

## Wire locations and Description

### RAD - 18

WIRE COLOR	CIRCUIT	PIN NUMBER	CIRCUIT	WIRE COLOR
White/Black	Left Front(-)	9	18	Not Used
Grey/Black	Right Front (-)	8	17	Left Front (+)
Green/Black	Left Rear (-)	7	16	Not Used
Purple/Black	Right Rear(-)	6	15	Right Front (+)
Black	Ground	5	14	Chime Module
Blue	SWC Output	4	13	Left Rear (+)
Orange	Illumination	3	12	Chime Module
Blue/White	Amp Turn On	2	11	Right Rear (+)
Red	+12v Accessory Output	1	10	+12v Constant

### OS-GM14

WIRE COLOR	CIRCUIT	PIN NUMBER	CIRCUIT	WIRE COLOR
Orange	Illumination	8	16	Amp Control
Purple/White	GMLan	7	15	+12v Constant
Black	Ground	6	14	Amplifier Turn On
Purple/Black	Right Rear (-)	5	13	Right Rear (+)
Green/Black	Left Rear (-)	4	12	Left Rear (+)
White/Brown	OnStar Mono(-)	3	11	OnStar Mono(+)
Grey/Black	Right Front (-)	2	10	Right Front (+)
White/Black	Left Front (-)	1	9	Left Front (+)

## Standard Bose®: Connecting to the vehicle's Bose® amplifier (All Other Listed Vehicles)

- Step 3-** The CM-X should be plugged into the white 2-pin connector and permanently mounted. This module will retain all warning chimes and audible turn signal indications. There is no volume adjustment for this feature so keep that in mind when choosing a mounting location.
- Step 4-** This amplifier will allow the fader to work correctly.
- Step 5-** The OnStar® volume is only able to be controlled from the adjustment screw on the interface. Make sure this is set to the desired level before mounting the interface and reassembling the dash.

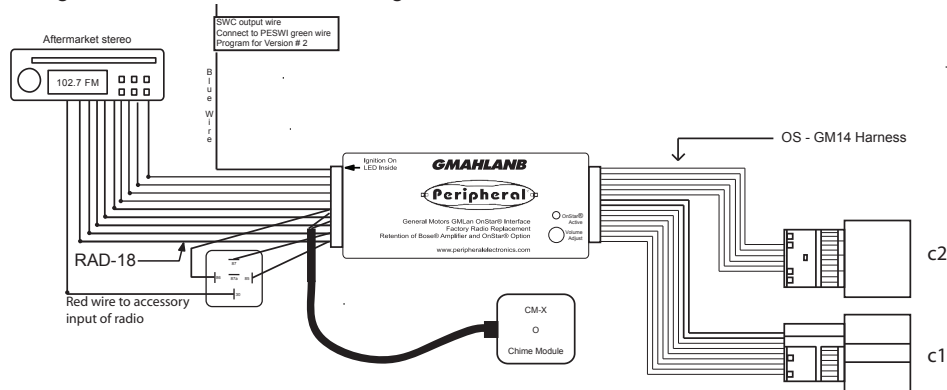

## Premium Bose®: Connecting to the vehicle's Bose® amplifier (Denali Only)

- Step 3-** The CM-X is not needed when the Premium Amplifier is retained. The door chimes and audible turn signal indicators are generated from the Bose® amplifier.
- Step 4-** OnStar® volume can be adjusted from the steering wheel buttons when OnStar® is activated (with premium Bose® amplifier ONLY). Turn the OnStar® volume adjustment on the interface all the way up.
- Note -** Due to the design of this Premium Bose® amplifier system, there is currently no way of fading from front to rear with an aftermarket radio.

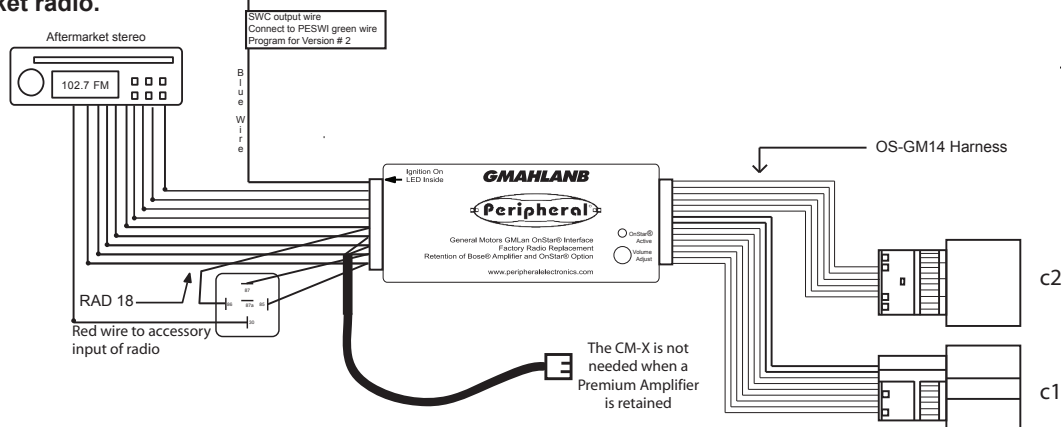

## Premium Bose®: Connecting to the vehicle's Bose® amplifier (Escalade Only)

- Step 3-** The CM-X is not needed when the Premium Amplifier is retained. The door chimes and audible turn signal indicators are generated from the Bose® amplifier.
- Step 4-** OnStar® volume can be adjusted from the steering wheel buttons when OnStar® is activated (with premium Bose® amplifier ONLY). Turn the OnStar® volume adjustment on the interface all the way up.
- Step 5-** This amplifier will allow the fader and balance to work correctly. You can also use the supplied brown connector, c4, for subwoofer control and center channel operation. These are low level mono inputs. We recommend using the center channel only if a 5.1 channel audio processor (or a dedicated center channel output) is present.

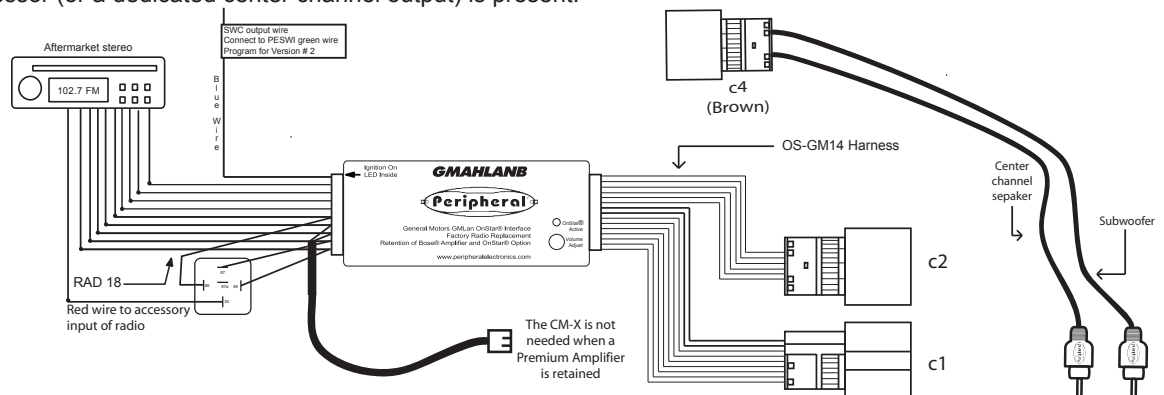

## Instructions for using the Rear Seat Audio jacks with a Dual Source head unit

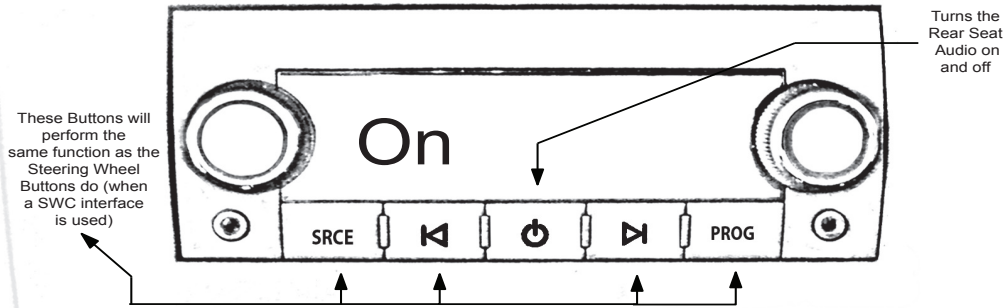

The headphone jacks will play the rear zone source selected by the head unit (refer to the new radios instruction manual for details on this feature if equipped). Maximize the rear zone volume level (this will reduce unwanted noise). During an Onstar call the front speakers play OnStar, the rear speakers are muted and the headphones will continue to play the rear zone audio source.

**Notes:** When the Rear Seat Audio jacks are activated in any vehicle OTHER than the Cadillac Escalade or GMC Yukon Denali the rear speakers will mute.

## Installation Notes

1. When the interface is connected to the vehicle for the first time the car must be started so all vehicle features are recognized by our interface.
2. If using a Navigation radio or other high current DVD LCD radio, do not connect the +12 volt constant and ground wires from the RAD-18 to your new radio. Jump these wires from the OS-GM14 to the new radio (refer to pin description on page 1 for wire locations).
3. **DO NOT** cut the Brown loop when connecting a PESWI Interface. Program the Interface for version # 2.

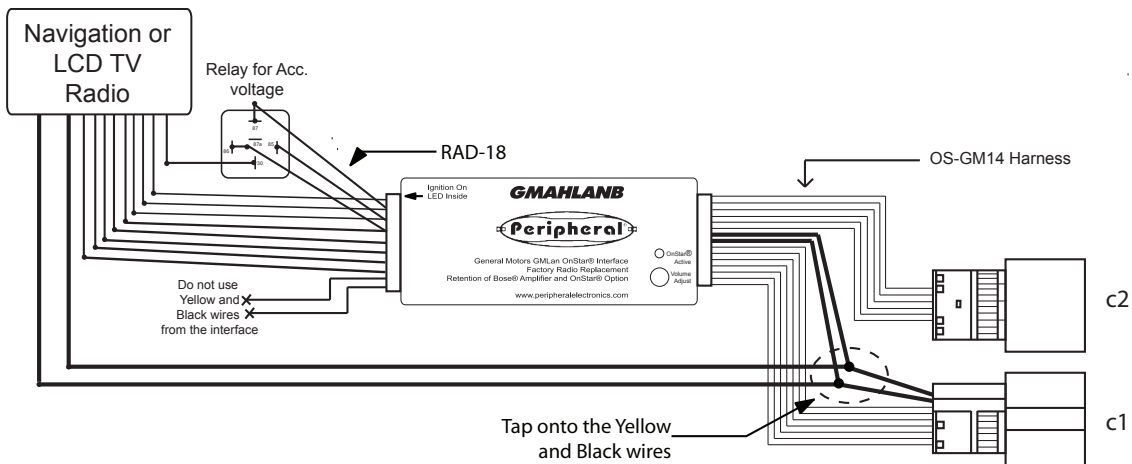

## Testing and Verifying Operation

1. Turn ignition on. The red ignition On LED inside the interface will turn on and the +12v accessory wire will turn on.
2. Turn on the radio and check balancing and fading. Note: **The Denali Premium Bose® amplifier will not fade as the rear outputs of after-market radio do not adjust the amplifier.**
3. Pressing the OnStar® button will turn off the rear speakers and allow the OnStar® audio to be heard in the two front speakers. The OnStar® active red LED will also turn on. When OnStar® disconnects, the radio will un-mute or turn back on and the OnStar® LED will turn off.
4. Turn off vehicle and remove key. RAP will be active and keep the radio on for 10 minutes or until the drivers door is opened.
5. The green LED and radio will turn off when RAP turns off or the drivers door is opened.
6. Pressing the Mute/OnStar® button on the steering wheel for 1.5 seconds will activate Onstar®.

**DISCLAIMER:** Under no circumstances shall the manufacturer or the distributors of the GMAHLANB parts be held liable for consequential damages sustained in connection with the GMAHLANB. The manufacture and it's distributors will not, nor will they authorize any representative or any other individual to assume obligation or liability in relation to the GMAHLANB other than its replacement.

**OnStar® is a registered trademark of OnStar® Corporation.**

**Bose® is a registered trademark of Bose®**